

STI BREAK GLASS STOPPER®



STI-6100

STI-4130

NOTE: Glass is clear — only appears dark for photo purposes.

PRODUCT OVERVIEW

Accepted by many fire marshals, these versions of the world famous STI Stopper II® are designed for areas where a "break glass" cover is specified, such as unsupervised areas. Each device consists of a red polycarbonate cover, mounting frame, a pane of single-strength clear glass (easily replaced when broken), a glass-breaking bar, screws and anchors for installation. Gaskets are also available to improve weather resistance.

HOW IT WORKS

Three models are available for fire, the smaller STI-6100, the larger STI-4100 and the STI-4130 for surface mount; the STI-4130 is the KIT-900-R conduit spacer and the STI-4100, the spacer will add two inches of depth and accommodate up to ¾" conduit. A fourth "generic" model (STI-6700) is available to cover devices other than manual pull stations. The same size as the STI-6100, it includes a wall mount hanging clip for keys, etc. This model for non-fire applications simply says, "BREAK GLASS."

KEY FEATURES

General Information

- Fire alarm remains clearly visible and accessible.
- Aesthetically appealing.
- Fast, easy installation.
- Accepted by many fire marshals. Obtain local fire marshal approval prior to installation.
- Three year guarantee against breakage of polycarbonate in normal use.

Design

- Glass replacement is simple. Suggestion: Order extra panes with each unit, for immediate replacement.

Construction

- Housing is molded of tough polycarbonate material.

Installation

- Typical working properties of polycarbonate are -40° to 250°F (-40° to 121°C).

Options

- Gaskets available to improve weather resistance.



STI Break Glass Stopper®

Dimensions and Technical Information

MODELS AVAILABLE

STI-4100	Break Glass Stopper - large
STI-4130	Kit containing both STI-4100 and KIT-900-R
STI-6100	Break Glass Stopper - small
STI-6700	Break Glass Stopper Keys Under Glass
KIT-08	Replacement break glass tool
KIT-09	Replacement glass for STI-6100
KIT-10	Replacement glass for STI-4100
KIT-67	Replacement glass for STI-6700 - reads "Break Glass"
KIT-900-R	2" Conduit Spacer (red) for STI-4100
KIT-6702	Tamperproof screw kit
KIT-H19016	Two tamper wrenches
STI-1280	Backplate for STI-4100
STI-3002	Weather gasket - large*
STI-3003	Conduit gasket 1/2"

*Gaskets may need to be trimmed prior to installation.

ACCESSORIES

Several accessories are available for the Break Glass Stopper. They include a polycarbonate mounting backplate (recommended for all installations with irregular mounting surfaces), additional spacer for stations with greater depth or exposed conduit and tamperproof screws (STI-4100 only).

NOTE

Local fire marshal approval should be obtained prior to installation.

WARRANTY

Three year guarantee against breakage of polycarbonate in normal use.

STI-6100 and STI-6700

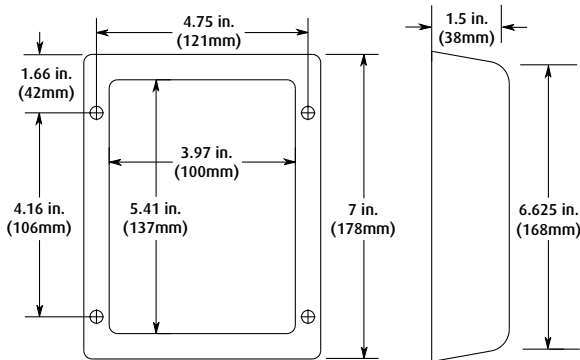

BACK VIEW

SIDE VIEW

STI-4100

SUB-900-R

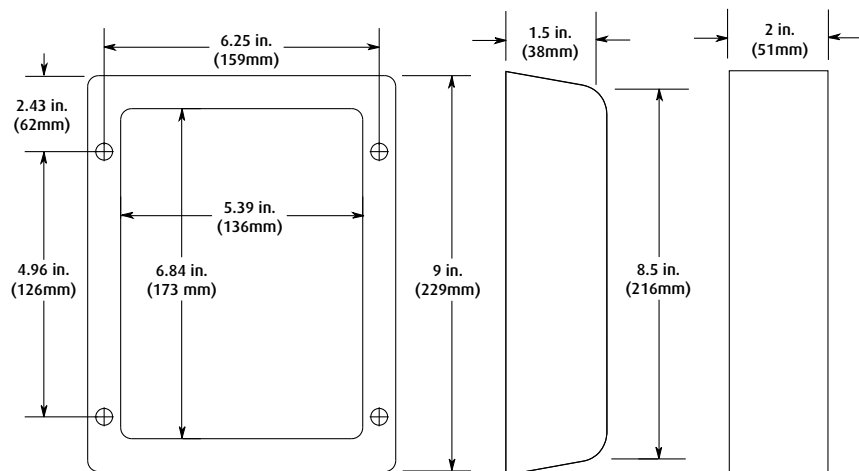

BACK VIEW

SIDE VIEW



**Safety Technology
International**